

MINISTRY OF EDUCATION
DEPARTMENT OF BASIC OF EDUCATION

NameAdm. No.

232/1 PHYSICS Paper 1

Time: 2 hours

END OF TERM 3 2024 - FORM THREE

Instructions to Candidates

- (a) Write your name and class Admission number in the spaces provided above.
- (b) Sign and write the date of examination in the spaces provided above.
- (c) This paper consists of **TWO** sections: **A** and **B**.
- (d) Answer **ALL** the questions in sections **A** and **B** in the spaces provided.
- (e) **ALL** working **MUST** be clearly shown.
- (f) Mathematical tables and nonprogrammable silent electronic calculators may be used.

For Examiner's Use Only

Section	Question	Maximum Score	Candidate's Score
A	1 –9	25	
B	10	13	
	11	18	
	12	7	
	13	11	
	14	6	
Total Score		80	

This paper consists of 11 printed pages. Candidates should check the question paper to ascertain that all pages are printed as indicated and that no questions are missing

SECTION (25 marks)

Answer all the questions in this section in the spaces provided

1. Draw the scale of a micrometer screw gauge with 50 divisions on the thimble scale reading 3.86mm

(2 marks)

2. The figure below shows a pump used to draw water from a well.

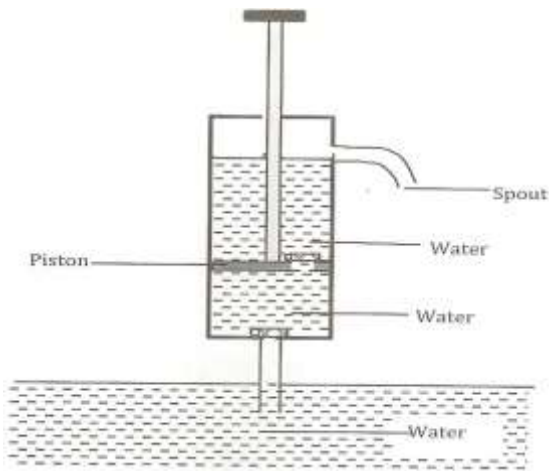

(i) What is its name. **(1 mark)**

.....

(ii) Give one limitation of using this type of a pump. **(2 marks)**

.....
.....

(iii) student pulls a block of wood along a horizontal surface by applying a constant force. State the reason why the block moves at a constant velocity. **(1mark)**

.....
.....
.....
.....

3. The figure below shows a flat-bottomed flask containing somewater. It is heated directly with avery hot flame.

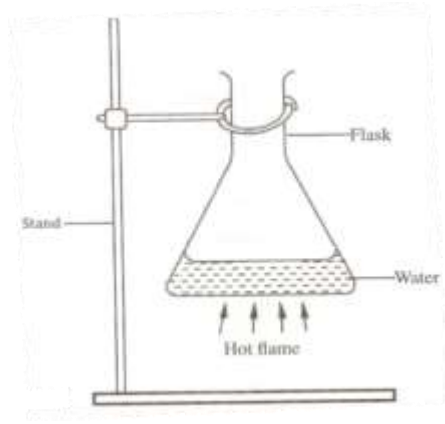

(a) Explain why the flask is likely to crack.

(2marks)

.....
 (b) Solid

weigh 16.5N on the surface of the moon. The force of gravity on the moon is 1.7N/kg. Determine the mass of the solid. **(2marks)**

.....

4. A bottle contains a smelling gas is opened at the front of a classroom. State the reason why the gas is detected throughout the room.

(1mark).....

.....

5. The diagram below shows apparatus used to observe the behaviour of smoke particle in air.

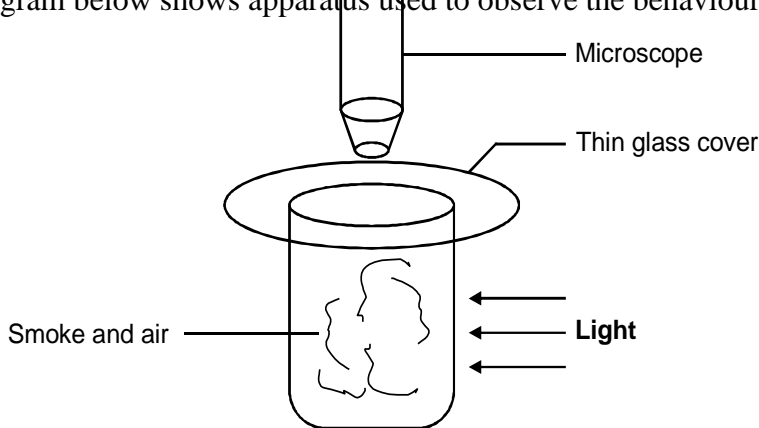

i) Why are smoke particles suitable for use in this experiment? **(1 mark)**

.....

ii) What does the experiment tell you about the behaviour of the air molecules in the cell?

(2 mark)

.....

 (iii) What difference if any would be seen in the motion of the smoke particles if a weaker light was used. (1 mark)

.....

6. State **three** environmental hazards that may occur when oil spills over a large surface area of the sea. (3marks)

.....

7. The three springs shown in Fig 11 are identical and have negligible weight. The extension produced on the system of springs is 20cm

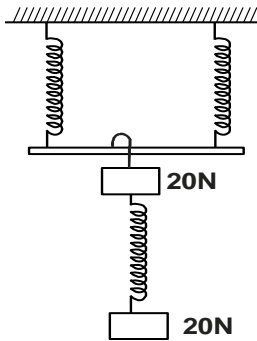

Determine the constant on each spring. (3 marks)

.....

8. The figure below shows an athlete lifting weights while standing with the feet apart.

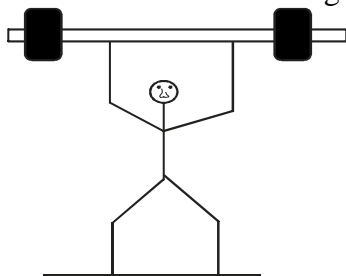

Explain why standing with the feet apart improves the athlete's stability. (2 mark)

.....

9. A girl blew air along the horizontal plane below the paper as shown in figure 5.

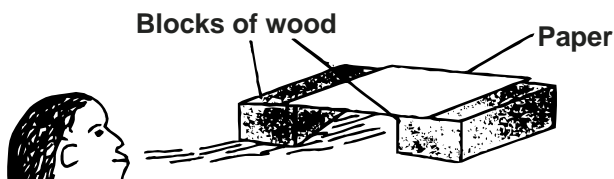

State and explain what would be observed.

(3 marks)

.....
.....

SECTION B (55 marks)

Answer all the questions in this section in the spaces provided

10. (a) Define the terms;

(i) Inelastic collision. **(1 mark)**

.....
.....

(ii) Impulse **(1 mark)**

.....
.....

(b) A bullet of mass 20g leaves the muzzle of a gun at a speed of 350m/s. If the mass of the gun is 3.5kg, calculate the recoil velocity of the gun. **(3 marks)**

.....
.....
.....
.....

(c) A block of mass 200g rests in a horizontal table. A force of 0.6N pulls the block so that it moves with a constant acceleration of 1m/s^2 calculate;

(i) The time it takes to travel a horizontal distance of 200m. **(3 marks)**

.....
.....
.....
.....

(ii)The frictional force between the block and the table **(2 marks)**

.....

(ii) The coefficient of kinetic friction between the two forces. **(2 marks)**

.....
.....
.....

(iii) A part from frictional force and the normal reaction name any other force. **(1mark)**

.....
.....
.....

11. (a) Define momentum and state its SI units (2marks)

.....
.....

(b) State the law of conservation of momentum. **(1 mark)**

.....
.....

(c) Two wheeled trolleys, X of mass 3kg and Y of mass 4kg are held together at rest against a compressed spring as shown in the figure below.

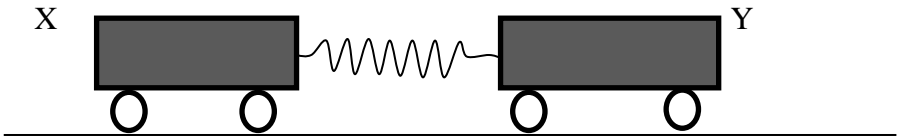

When the trolleys are released at the same instant, X moves to the left at 8m/s. calculate;

(i) The velocity of Y immediately after the release. **(3 marks)**

.....
.....
.....

(ii) The kinetic energy of X and Y after release. **(4 marks)**

.....
.....
.....
.....

(iii) Calculate the compression of the spring given that it has a spring constant of $1.0 \times 10^4 \text{N/m}$. **(3 marks)**

.....

(d) An arrow of mass 20g traveling horizontally strikes a block of wood of mass 1980 g resting on a horizontal surface. The impact takes 0.2 seconds before the two moves together with an initial velocity of 5m/s. Calculate;

(i) The velocity of the arrow before the impact. (3 marks)

.....

ii) The force of impact. (2 marks)

.....

12. a) The diagram below shows a set up used by a student to show variation of pressure in a liquid. Use it to answer the question that follow.

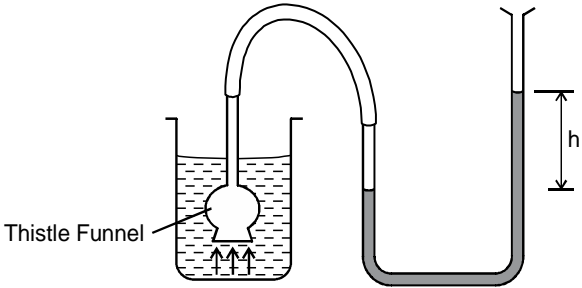

State and explain the effect on the height, h, when the thistle funnel is moved upwards towards the surface of the liquids. (2 marks)

.....

b) Figure below shows a simple barometer.

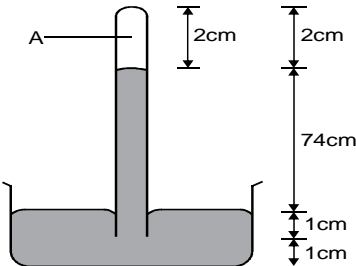

What is the region A?

(1 mark)

.....

(i) What keeps the mercury in the tube? (1 mark)

.....

(ii) What is the value of the atmospheric pressure being shown by the barometer? (1 mark)

.....

.....

(iii) What would happen to the reading if the barometer were taken up a high mountain. (1 mark)

.....

.....

(iv) Give a reason for (d) above. (1 mark)

.....

.....

13. The speed of a train, hauled by a locomotive varies as shown below as it travels between two stations along a straight horizontal track.

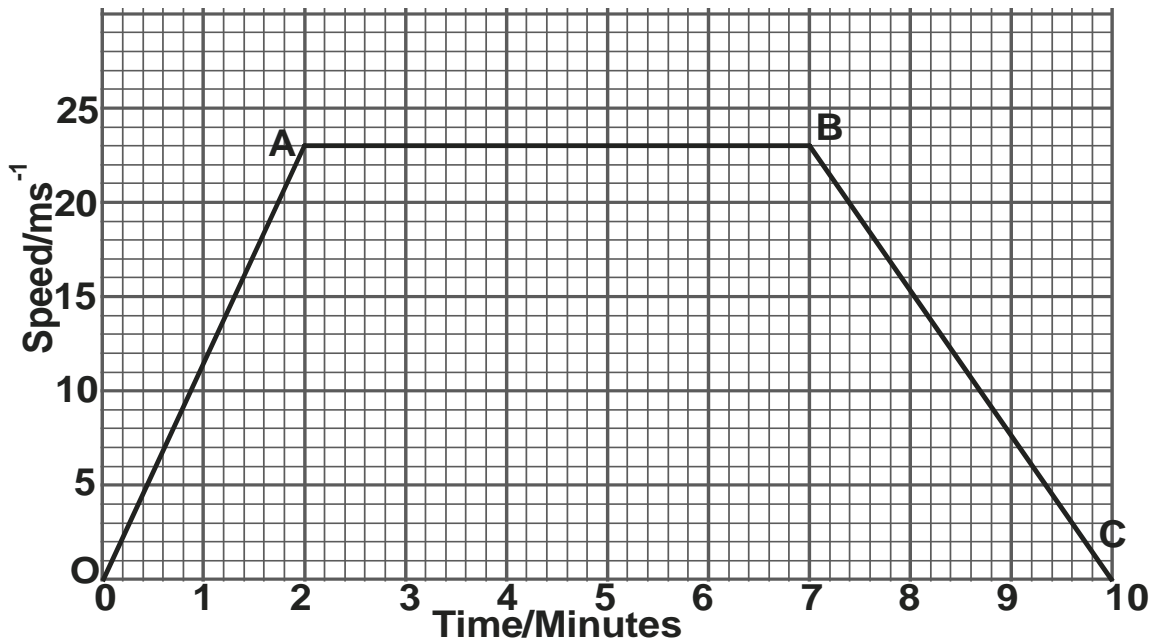

Use the graph to determine:

(i) the maximum speed of the train. (1 mark)

.....

.....

(ii) The acceleration of the train during the first 2mins of the journey. **(2 marks)**

.....

.....

The time during which the train is slowing down. **(2 marks)**

.....

.....

.....

(iii) The total distance, in metres, between the two stations. **(4 marks)**

.....

.....

.....

.....

(iv) The average speed in ms^{-1} of the train. **(2 marks)**

.....

.....

.....

14 .a) The figure below shows a pulley system being used to raise a load.

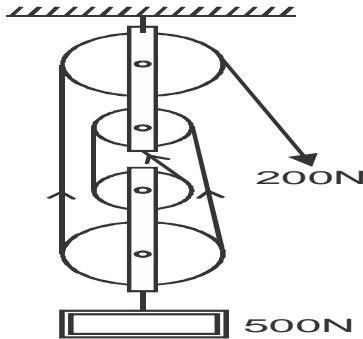

Given that the size of the load is 500N and the effort applied is 200N, calculate the efficiency of the machine. **(3 marks)**

.....

.....

.....

- b) A pendulum bob is raised to a height of 60cm above its lowest point and made to swing as shown in the figure.

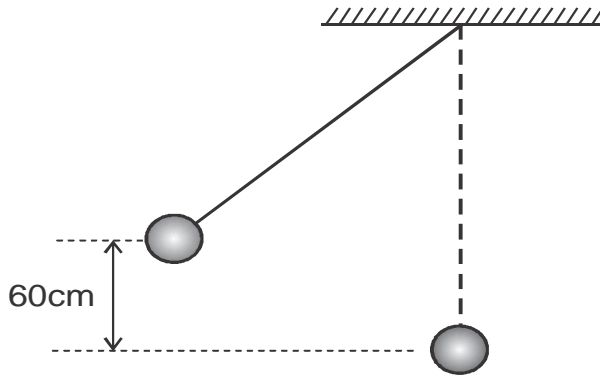

Determine the velocity of the mass at the height where kinetic energy is equal to the potential energy.
(3 marks)

.....

